

PRODUCT INFORMATION PACKET

Model No: 449TSTGS16506

Catalog No: E595A

250 HP, Explosion Proof NEMA Motors, 3 phase, 3600 RPM, 460 V, 449TS Frame, EPFC
Explosion Proof NEMA Motors



Regal and Marathon are trademarks of Regal Beloit Corporation or one of its affiliated companies.
©2020 Regal Beloit Corporation, All Rights Reserved. MC017097E

REGAL

Nameplate Specifications

Output HP	250 Hp	Output KW	187.0 kW
Frequency	60 Hz	Voltage	460 V
Current	270.0 A	Speed	3575 rpm
Service Factor	1	Phase	3
Efficiency	95.8 %	Power Factor	89
Duty	Continuous	Insulation Class	F
Design Code	B	KVA Code	G
Frame	449TS	Enclosure	Explosion Proof Fan cooled
Thermal Protection	Thermostats (N/C)	Ambient Temperature	40 °C
Drive End Bearing Size	6313	Opp Drive End Bearing Size	6313
UL	UL Listed And CSA Certified	CSA	Y
CE	N	IP Code	54
Hazardous Location	EXP PROOF CL I GR C&D CL II GR F&G T3B		

Technical Specifications

Electrical Type	Squirrel Cage Inverter Rated	Starting Method	Line Or Inverter
Poles	2	Rotation	Reversible
Resistance Main	.0086 Ohms	Mounting	Rigid Base
Motor Orientation	Horizontal	Drive End Bearing	Ball
Opp Drive End Bearing	Ball	Frame Material	Cast Iron
Shaft Type	TS	Overall Length	28.25 in
Frame Length	28.77 in	Shaft Diameter	2.375 in
Shaft Extension	5.00 in	Assembly/Box Mounting	F1 ONLY
Connection Drawing	A-EE7300S	Outline Drawing	B-SS515927-2875

B

B

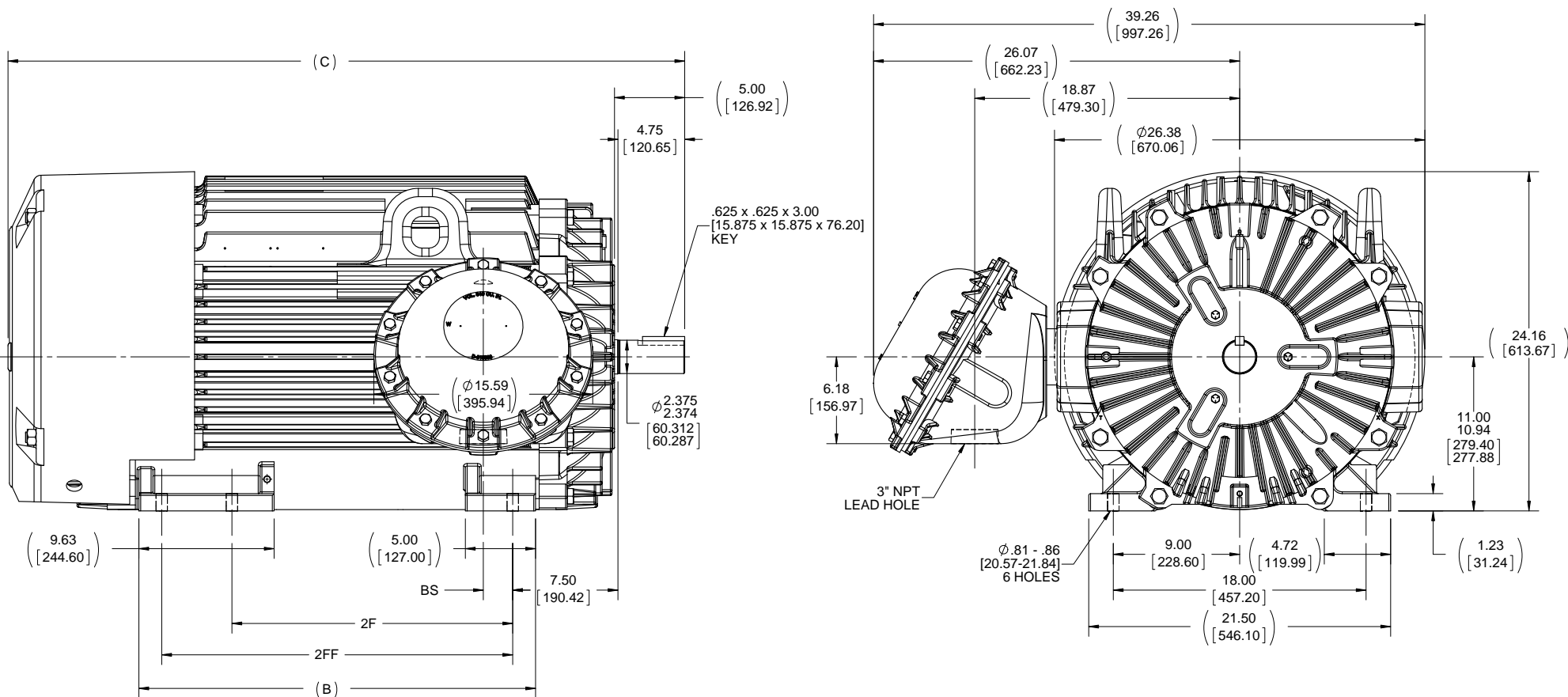

A

A

- NOTES:
 1. CONDUIT BOX CAN ONLY BE ROTATED CLOCKWISE UP TO 270° FROM ITS ORIGINAL POSITION.
 2. NAMEPLATES TO BE READ FROM CONDUIT BOX SIDE OF MOTOR.
 3. DIMENSIONS IN [] ARE IN MILLIMETERS.

DASH	FRAME	B	C	2F	2FF	BS
2875	447TS	28.25 [717.55]	48.19 [1224.03]	20.00 [508.00]	---	2.09 [53.09]
2875	449TS	28.25 [717.55]	48.19 [1224.03]	---	25.00 [635.00]	2.09 [53.09]

DRAWING REVISION E	REVISION BY JJB	DATE 01-05-2017
ECO ECO-0114341	APPROVED BY TDB	DATE 01-05-2017
ECO DESCRIPTION UPDATED TO CURRENT STANDARDS		
<small>COPYRIGHT REGAL BELOIT AMERICA, INC. ALL RIGHTS RESERVED. PROPRIETARY AND CONFIDENTIAL INFORMATION - THIS DOCUMENT IS THE PROPERTY OF REGAL BELOIT AMERICA, INC. (OWNER) AND CONTAINS OWNER'S PROPRIETARY INFORMATION. ANY PERSON, CORPORATION OR OTHER FIRM RECEIVING IT IS DEEMED, BY RECEIVING IT, TO AGREE THAT IT, AND/OR ANY PART OF IT, SHALL NOT BE DISCLOSED TO ANY PERSON, CORPORATION OR OTHER ENTITY, DUPLICATED, AND/OR USED, EXCEPT AS EXPRESSLY APPROVED IN WRITING IN ADVANCE BY OWNER. THIS DOCUMENT SHALL BE RETURNED TO OWNER UPON REQUEST. IT MAY BE SUBJECT TO CERTAIN RESTRICTIONS UNDER APPLICABLE EXPORT CONTROL LAWS AND REGULATIONS.</small>		

TOLERANCES UNLESS OTHERWISE SPECIFIED:		
DEC.	INCH	mm
.X	+0.1	[+2.5]
.XX	+0.03	[+0.76]
.XXX	+0.005	[+0.127]
.XXXX	+0.0005	[+0.0127]
REMOVE BURRS & BREAK SHARP EDGES: .003/.015 [.076/.381] X 45°		
CORNER FILLETS: R.02 [.51]		
MACHINED SURFACES: 200 / 5.1		
mm SHOWN IN [BRACKETS]		

DRAWN BY CM
DATE 3-10-2014
APPROVED BY DJK
DATE 3-14-2014
REFERENCE
THIRD ANGLE PROJECTION

Regal Beloit America, Inc.	
DESCRIPTION OUTLINE 447/449TS FR. - TEFC - STD. - EX. PR.	
MATERIAL	PROCESS/FINISH
SIZE B	DRAWING NUMBER SS515927
	SHEET 1 OF 1

EE7300S

THREE PHASE – SINGLE VOLTAGE MOTOR

TO REVERSE ROTATION:
INTERCHANGE ANY TWO LINE
LEAD CONNECTIONS

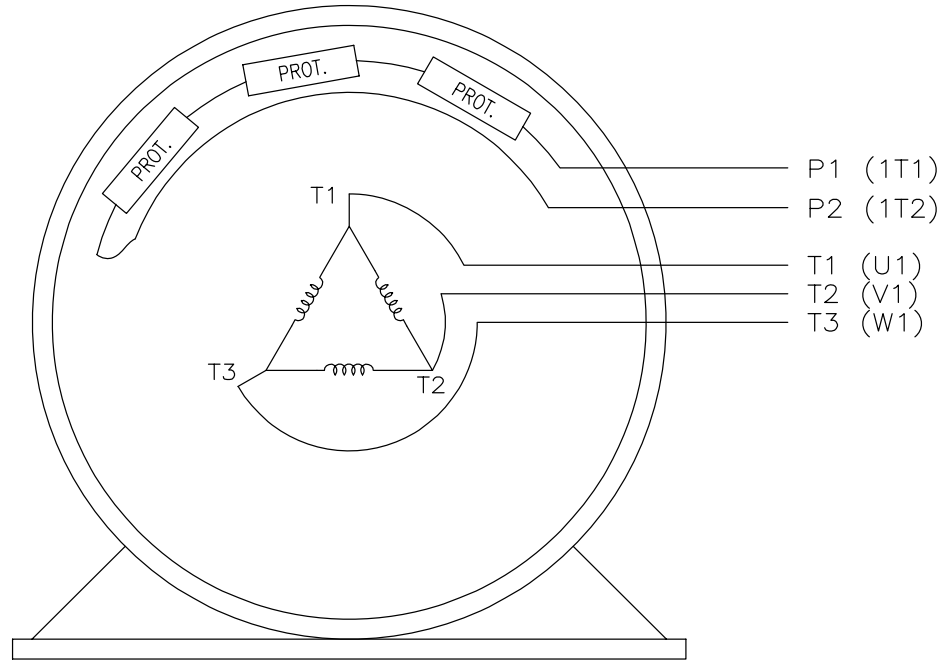

VIEW OF TERMINAL END

IF MOTOR HAS MULTIPLE
T'S PER LEAD CONNECT
TOGETHER LIKE T'S

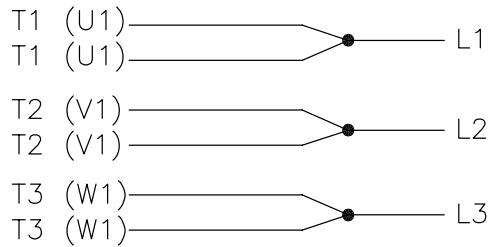

A-9806 DECAL

NO.	REVISION	BY & DATE	CHK	TOLERANCES UNLESS SPECIFIED		FINISH	DRAWN	PAGE	OF	REV.
				DEC.	INCHES					
F	UPDATED TITLE BLOCK	HV 02-27-2014	EWJ	.X	± -		KL	12-15-1999		
3	REMOVED "N.C." FROM PROT.'S MU61770	JJB 08-02-2010		.XX	± -		DJK	12-15-1999		
2	ADDED IEC MARKINGS MU61770	KL 09-16-2004	EAB	.XXX	± -	TITLE CONNECTION DIAGRAM – EXTERNAL SINGLE VOLTAGE 3Ø MOTOR	APPD	DJK	12-15-1999	SCALE 1=1
1	NEW DRAWING	KL 12-16-1999		.XXXX	± -	MAT'L				REF
				ANG	± -					FMF
										PREV
THIS DRAWING IN DESIGN AND DETAIL IS OUR PROPERTY AND MUST NOT BE USED EXCEPT IN CONNECTION WITH OUR WORK ALL RIGHTS OF DESIGN AND INVENTION ARE RESERVED THIS IS AN ELECTRONICALLY GENERATED DOCUMENT – DO NOT SCALE THIS PRINT						RFP	CAD FILE	ee7300s	SIZE	DRAWING NO. PAGE OF REV.
						DIST	WA-LB-SB	A	EE7300S	F





P.O. BOX 8003
WAUSAU, WI 54401-8003
PH. 715-675-3311

DATA VOLTS: 460

CERTIFICATION DATA SHEET

CUSTOMER P.O. #:
 ORDER #: A-EE7300S
 REFERENCE MODEL #: 449TSGS16506
 CONN. DIAGRAM: B-SS515927-2875
 CAT #: E595A
 OUTLINE: T4492120
 CUSTOMER PART #:
 WINDING: NONE 1
 MOUNTING: F1 ONLY
 SPEED:
 TYPICAL MOTOR PERFORMANCE DATA

HP	KW	SYNC RPM	FL RPM	FRAME	ENCLOSURE	TYPE	KVA CODE	DESIGN
250	187	3600	3575	447/449TS	TEFC	TEN	G	B

PH	HZ	VOLTS	AMPS	START TYPE	DUTY	INSL	S.F.	AMB	ELEV.
3	60/50	460#380	270#265	LINE OR INVERTER	CONT	F	1.15	40	3300
	F.L. EFF	95.8	3/4 LD EFF	95.4	1/2 LD EFF	94.5	GTD EFF	ELECT. TYPE	
	F.L. PF	89.0	3/4 LD PF	88.0	1/2 LD PF	83.0	95.0	SO CAGE INV BATED	

F.L. TORQUE	LR AMPS @ 460 V	L.R. TORQUE	B.D. TORQUE	F.L. RISE (°C)
367 LB-FT	1.825	650 LB-FT	1.050 LB-FT	286%
@ 3 FT.	POWER	ROTOR WK ²	MAX. LOAD WK ²	SAFE STALL TIME
82 DBA	91 DBA	51.0 LB-FT ²	0 LB-FT ²	0 SEC.
				START/SHOUR
				0
				MOTOR WGT
				2800 LB.

*** SUPPLEMENTAL INFORMATION ***

DE BRACKET TYPE	ODE BRACKET TYPE	MOUNT TYPE	MOTOR ORIENTATION	SEVERE DUTY	HAZARDOUS LOCATION	DRIP COVER	SCREENS	PAINT
STANDARD	STANDARD	RIGID	HORIZONTAL	UM SEVERDPL CL I GR C&D CL I I GR	NO	NO	NONE	BLUE (EPOXY)
BEARINGS		GREASE	SHAFT TYPE	SPECIAL DE	SPECIAL ODE	SHAFT	MATERIAL	FRAME MATERIAL
DE BALL 6313	ODE BALL 6313	POLYREX EM	TS	NONE	NONE	1045 HOT ROLLED (C-204)	NONE	CAST IRON

THERMOSTATS	PROTECTORS	WDG RTD's	BRG RTD's	THERMISTORS	CONTROL	SPACE HEATERS
TSTATS (N/C)	NOT	NONE	NONE	NONE	FALSE	NA
R1 (ohms/ph)	R2 (ohms/ph)	X1 (ohms/ph)	X2 (ohms/ph)	Xm (ohms/ph)	VIBRATION (in/sec)	FLOAT
0.007	0.007	0.085	0.087	3.78	0.080	ODE

* N		INVERTER TORQUE: CONSTANT 2:1	
O		INV. HP SPEED RANGE: NONE	
T		ENCODER: NONE	
E		BRAKE: NONE	
S		FT-LB: NONE	
		VOLTAGE: NONE	
		HZ: NONE	

PREPARED BY: FAREEDA DUDEKULA
 DATE: 9/10/2018
 FORM: 3531 REV 4 2/27/06

